

500-EXCELLENT SERIES MB-MODELS



- A heavy duty free standing disposer for compact working area
- Disposer outlet can be positioned to suit existing drain installation
- Delivered ready for installation
- Det Norske Veritas Approval for compliance with MARPOL Annex V

The MB-unit is the perfect choice of food waste disposer for kitchens and galleys where space is limited.

These units are designed to be installed as separate units, and are delivered ready for connecting to existing flushing water, drainage and electrical supplies. The positioning of the waste water outlet can be adjusted to suit the position of the existing drain.

MB models has a flushing nozzle connected to a solenoid valve and a line strainer. When

the disposer is started, the solenoid valve opens allowing water to flush food waste into the grinding unit and out to the wastewater system.

The lid is fitted with a limit switch, which stops the disposer motor when the lid is lifted. This prevents access to the rotating grinding unit during operation.

The Disperator 500 Excellent Series has Det Norske Veritas (DNV) Approval for compliance with IMO MARPOL 73/78 ANNEX V for disposal of ground food waste into the open sea.

Further details are specified overleaf.

500-EXCELLENT SERIES MB-MODELS

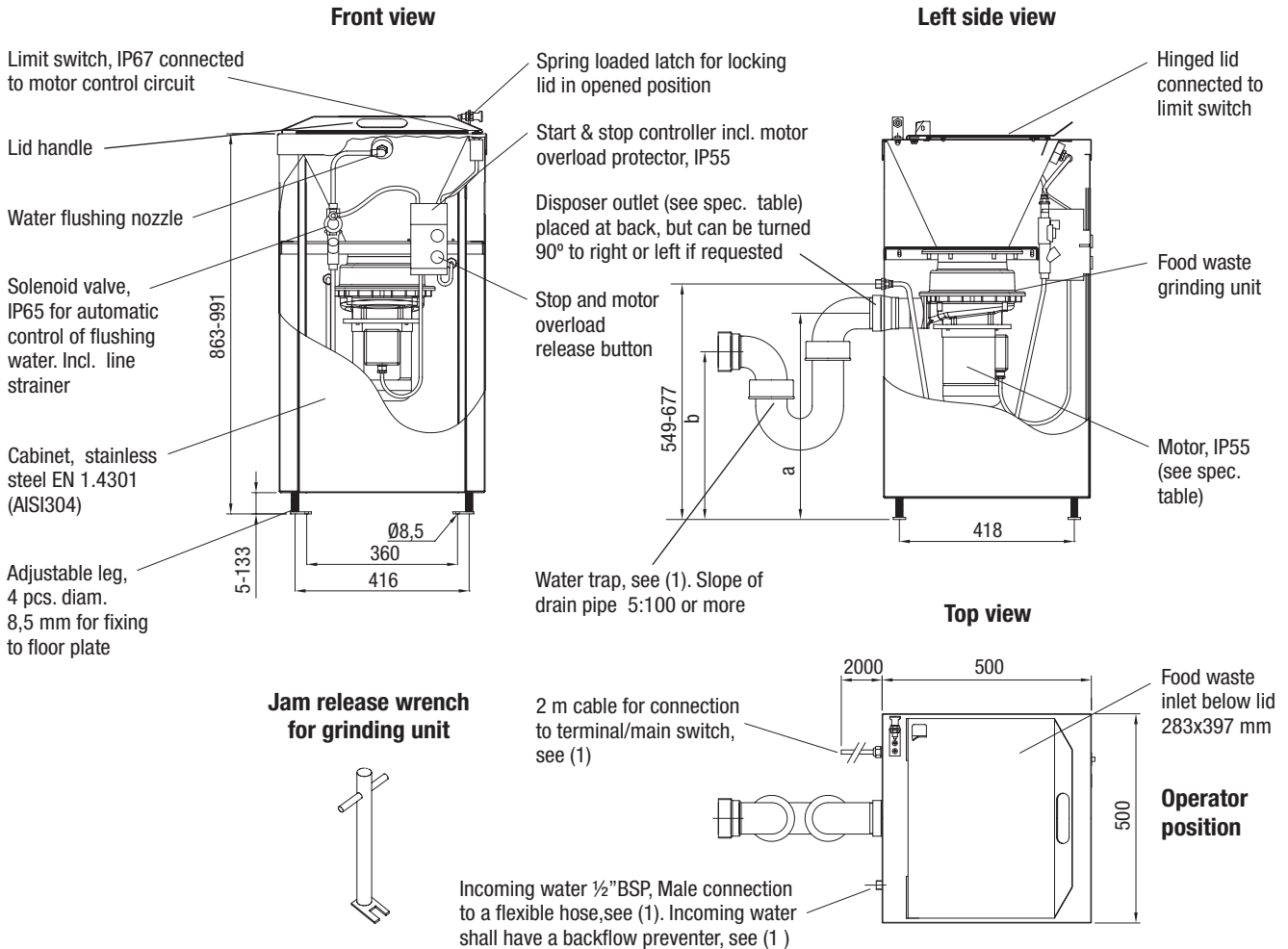

All measurements in mm

Technical Specification	510-MB	515-MB	520-MB	530-MB	550-MB	575-MB
Normal capacity, kg/hr	300	400	500	700	850	1000
Electrical power, kW	0,75	1,1	1,5	2,2	4,0	5,5
Rated current, A, for						
230V / 3ph / 50Hz	4,0	5,2	7,2	9,5	14,8	19,7
400V / 3ph / 50Hz	2,3	3,0	4,1	5,2	8,6	11,5
440V / 3ph / 60Hz	2,1	2,7	3,8	5,2	7,8	11,6
Other 3-ph voltages available						
Control voltage	Marine installation: the same as motor voltage. Land installation: 230V/50Hz					
Fuse rating, slow	10 A	10 A	10 A	16 A	16 A	25 A
Disposer outlet connection	2 "	BSP,	Female	2 1/2 "	BSP,	Female
Height of disposer outlet (a)	a = 501 – 629			a = 466 – 594		
Ditto for water trap (b)	b = 449 – 577			b = 434 – 562		
(if ordered from Disperator)						
Gross / net weight, kg	70 / 59	70 / 59	71 / 60	91 / 80	96 / 85	99 / 88

(1) Installation material needed but not incl. in standard delivery are terminal or main switch; flexible hose 1/2" BSP, Female; back-flow preventer and water trap. Can be ordered from DISPERATOR.

Installation, operation and service instructions are together with this product leaflet included in delivery.

